



3-year
warranty

V358 / V438 (L or S)
Fish skinners

for
flat fishes, big
fresh or smoked
fish fillets

Manual machines for close-to-skin to deep skinning of your products

- ▶ Easy to use
- ▶ Femoral control
- ▶ Water or air injection
- ▶ Interchangeable blade holder and/or skinning shoe

V358 / V438 (L or S) – Manual fish skinners

The V358 and V438 are two manual machines designed for close-to-skin or deep skinning* as well as skinning operation** of flatfish (sole, plaice, dab, skate wing) and large fresh or smoked fillets (trout and salmon).

Each model is available in an L* and S** version and **differs in working width**, allowing the machine to be matched to the size of the fillets being processed as well as space constraints.

Both versions work on fresh or smoked products, with manual or automatic water or air injection management.

The bearing roller (see inset) improves safety, comfort and final product quality.

* **L version** – standard shallow and deep skinning: its comb roller and thickness-adjustable blade ensure deep membrane skinning and reduce brown muscle..

** **S version** – skinning operation: equipped with a skinning shoe for precise silver skinning.



Key features

1. Easy to use, no specific maintenance
2. Femoral control
3. Thickness adjustment via handle (L version)
4. Water or air injection
5. 3 working widths: 488, 400 or 320 mm
6. Toothed roller combined with a comb
7. Quick and easy cleaning with water hose (tool-free removable blade holder and tilting comb)
8. 100% stainless steel

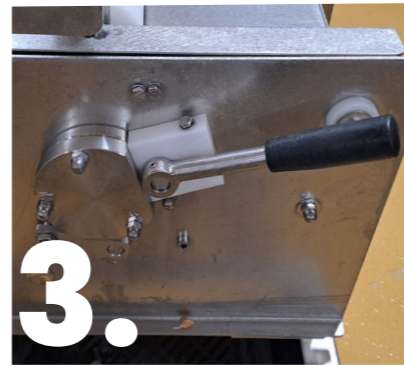

The handle located on the side of the L version machine allows for height adjustment.

Available Options

- ▶ Bearing roller
- ▶ Skinning shoe (for L version)
- ▶ Manual skin recovery from the front (foot pedal control replaces femoral control)
- ▶ Single-phase 230V
- ▶ Solenoid valve for water or air injection



To facilitate product processing, the use of the **bearing roller** (optional) is recommended.

The feed roller delivers more consistent skinning quality. It also provides greater ease of use: simply push the product flat, without lifting it.



Smoked fish skinned with the V358S machine (left) and deep-skinned smoked fish with the V358L (right)

Technical information

Capacity: 20 pieces/min
Working width: 488, 400 or 320 mm
Feed speed: 17 m/min
Weight: 85, 70 and 55 kg
Standard power connection: 400 V three-phase, 50 Hz*
Power consumption: 0.55 kW three-phase

* other power connection available upon request



3-year warranty

Flash this QR code to watch the video introducing the machines:

V438
(skate wing)



V358L
(smoked salmon)



V358S
(sole)



Layout diagram

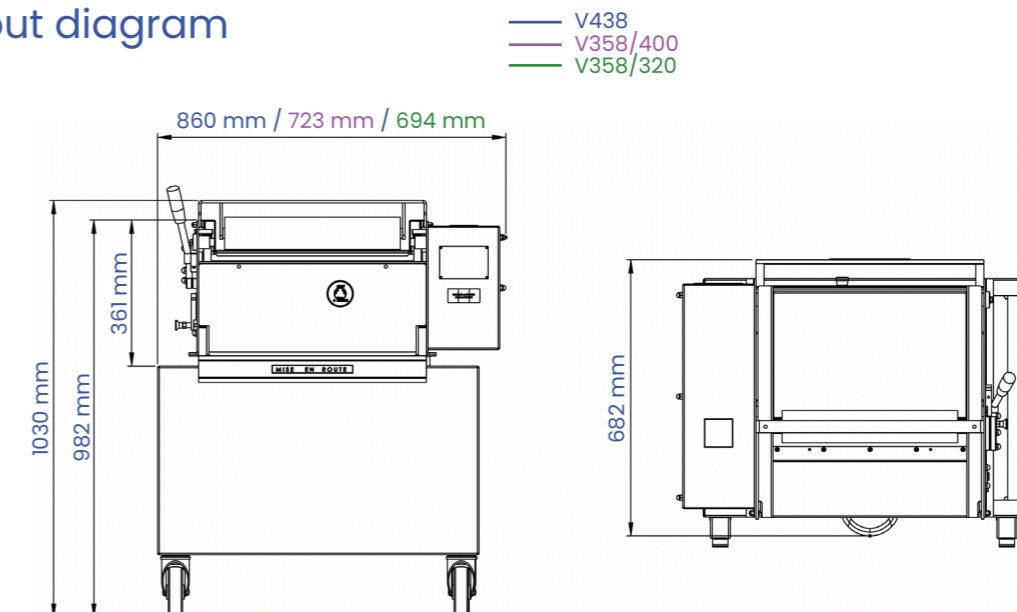



VARLET MACHINES

Founded in 1933, Varlet Machines is a French company based in Boulogne-sur-Mer, which designs, manufactures and sells machines for processing fish, meat and poultry.

With an experience of more than 80 years and the will to answer the more and more demanding expectations of the market, the company is today the first French manufacturer of machines in this field.



Varlet Machines, 12-14, rue de Magenta,
62200 BOULOGNE-SUR-MER, FRANCE



Tel. : +33 (0)3 21 31 49 26



contact@varletmachines.com



www.varletmachines.com