



**3-year**  
warranty

**V2602P / V2902P / V3902P**  
Automatic slicers

for  
**all types of fish,**  
**fresh or smoked**

***Automatic machines*** for consistent,  
uniform-thickness slicing of your fish

- ▶ Easy to use
- ▶ Single blade for all fish types
- ▶ Continuous thickness adjustment
- ▶ Automatic water injection: product and machine rinsing
- ▶ No prior product preparation required

## V2602P / V2902P / V3902P – Automatic slicers

The V2602P, V2902P, and V3902P slicers are designed for **consistent, uniform-thickness slicing of all types of fish**: salmon steaks and fillets, tuna loins and seafood products in general, whether fresh or smoked.

These machines are distinguished by their processing capacity:

- V2602P: suited for half-loins
- V2902P: suited for whole loins
- V3902P: high capacity, for loins up to 105 cm in length and thicker cross-sections

Slice thickness is adjustable from **3 to 50 mm**, with a cutting rate of **160 cuts/min** (standard) and **500 kg/hour**. **Continuous feed ensures consistent, even slices**. No prior chilling or freezing is required.

**Please note: these machines are not suitable for frozen products. tranches.**

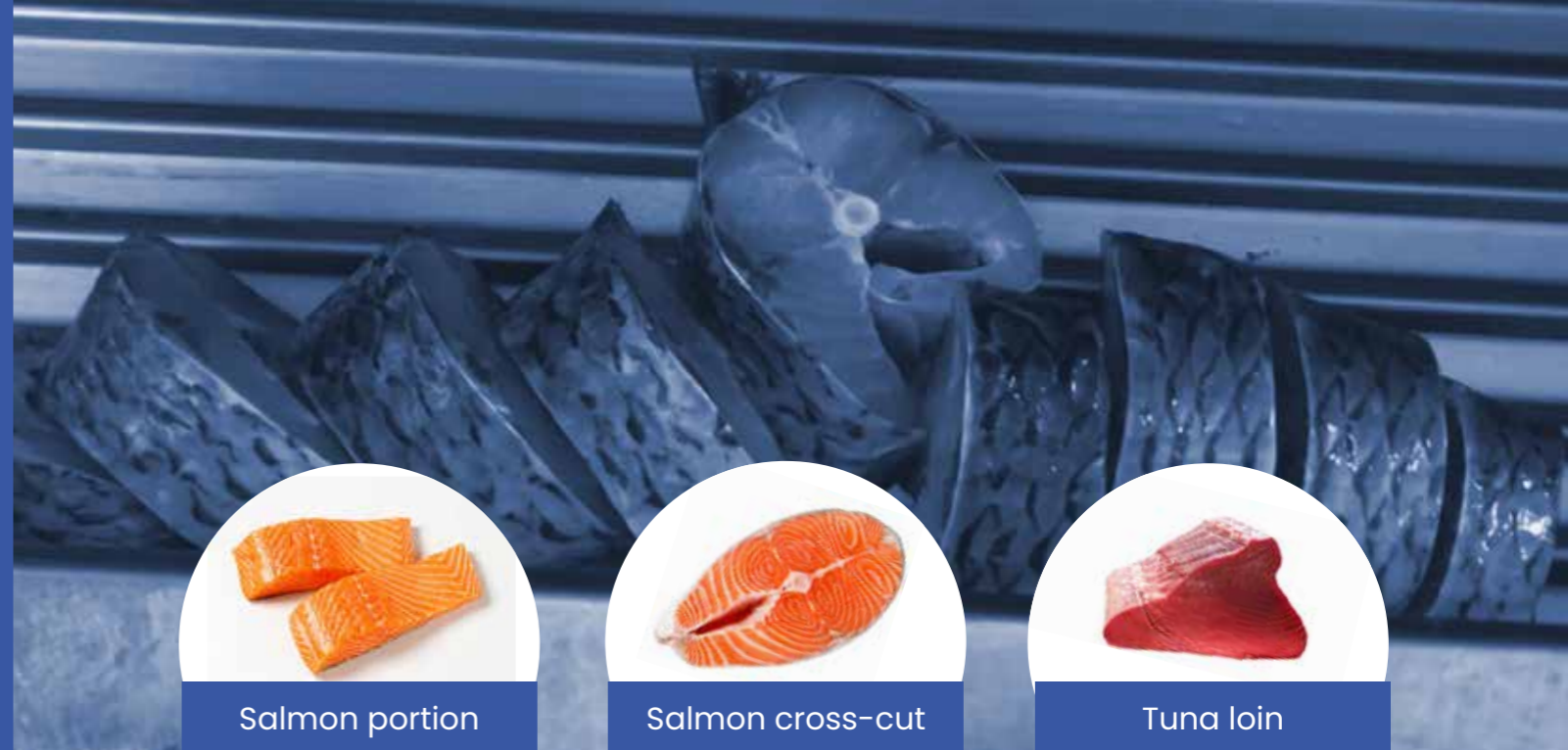

## Key features

1. Easy to use: 5-button interface
2. Adjustable slice thickness during operation (potentiometer)
3. Single standard cutting speed
4. Quick blade removal
5. Built-in water injection for rinsing the blade and sliced fish
6. Handheld spray nozzle for machine washdown
7. 100% stainless steel



The potentiometer's "sensitivity" allows for optimal slice thickness adjustment.

## Technical information

**Capacity:** 160 cuts/min  
**Slice thickness:** 3 to 50 mm  
**Weight:** 222 kg (V2602P)  
**Standard power connection:** 400 V three-phase, 50 Hz\*  
**Power consumption:** 2.7 kW

\* other power connection available upon request

### Available options

- ▶ 2nd cutting speed (for fine slicing and/or increased throughput)
- ▶ Vertical discharge (V2602P / V2902P)
- ▶ Counter-pressure block

Flash this QR code to watch the video introducing the V2602P slicer:

V2602P (carp)      V2602P (salmon)



## Schémas d'implantation (V2602P)

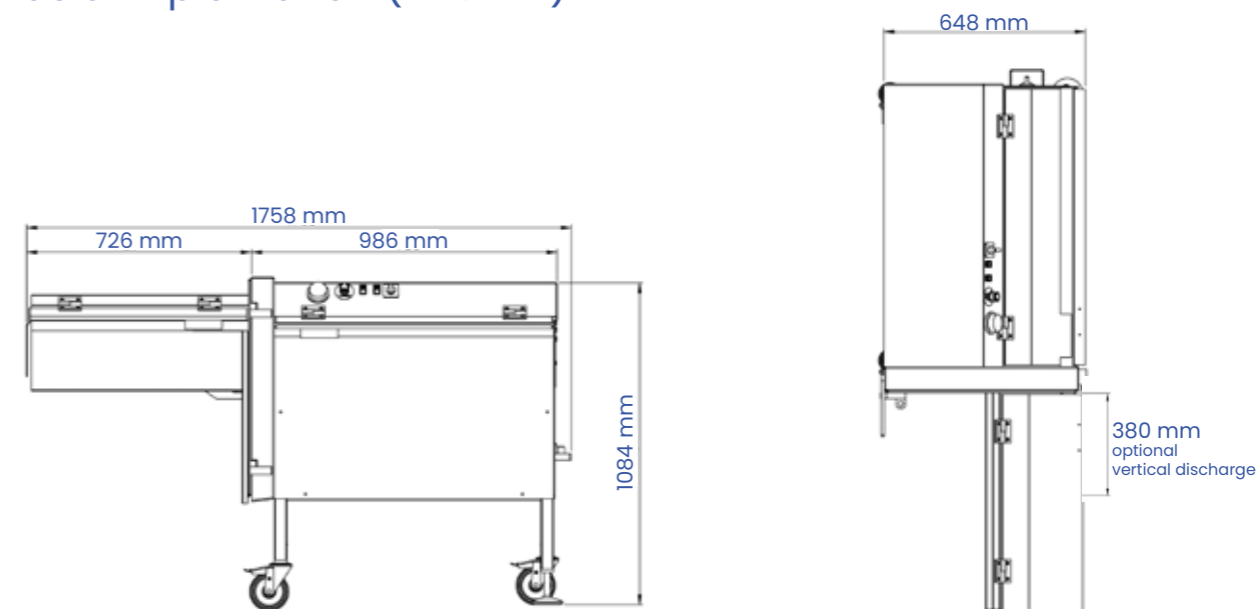

Contact us for the dimensions of the V2902P and V3902P machines: [contact@varletmachines.com](mailto:contact@varletmachines.com)



## VARLET MACHINES

Founded in 1933, Varlet Machines is a French company based in Boulogne-sur-Mer, which designs, manufactures and sells machines for processing fish, meat and poultry.

With an experience of more than 80 years and the will to answer the more and more demanding expectations of the market, the company is today the first French manufacturer of machines in this field.



Varlet Machines, 12-14, rue de Magenta,  
62200 BOULOGNE-SUR-MER, FRANCE



Tel.: +33 (0)3 21 31 49 26



[contact@varletmachines.com](mailto:contact@varletmachines.com)



[www.varletmachines.com](http://www.varletmachines.com)